

SCHEMA DI MONTAGGIO

PERGOLA DECO'

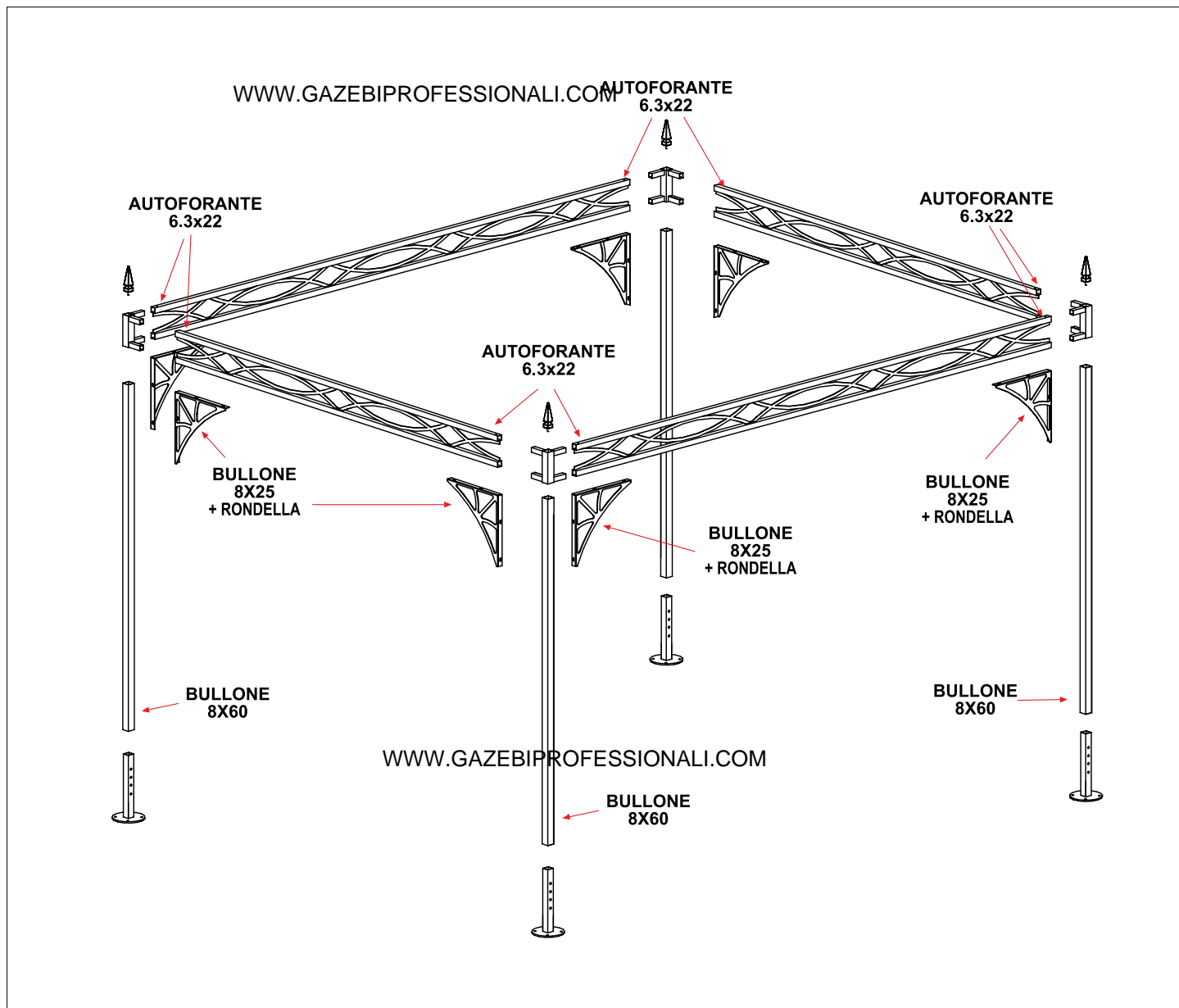

BULLONERIA

PARTE DA MONTARE	BULLONE	QUANTITÀ
<input type="checkbox"/> GIUNZIONE TRAVE - ANGOLO	AUTOFORANTI 6.3x22	16
<input type="checkbox"/> PIANTONE CON PIEDE	8x60	4
<input type="checkbox"/> SQUADRI ANGOLARI	8x25 + rondella	32
<input type="checkbox"/> TAPPI PER TRVERSE SCORREVOLI	viti 5x60	4 per traversa
<input type="checkbox"/> PORTA-BINARIO	6X30	1 per inserto filettato
<input type="checkbox"/> DECORO PER ANGOLO (<input type="checkbox"/> LANCIA <input type="checkbox"/> SFERA)		4
<input type="checkbox"/> TAPPI PER ANGOLOLO		
<input type="checkbox"/> BULLONE BLOCCA TRAVERSE	6x60	2
<input type="checkbox"/> FERMI BLOCCA TRAVERSE		1 DX e 1 SX



WWW.GAZEBIPROFESSIONALI.COM

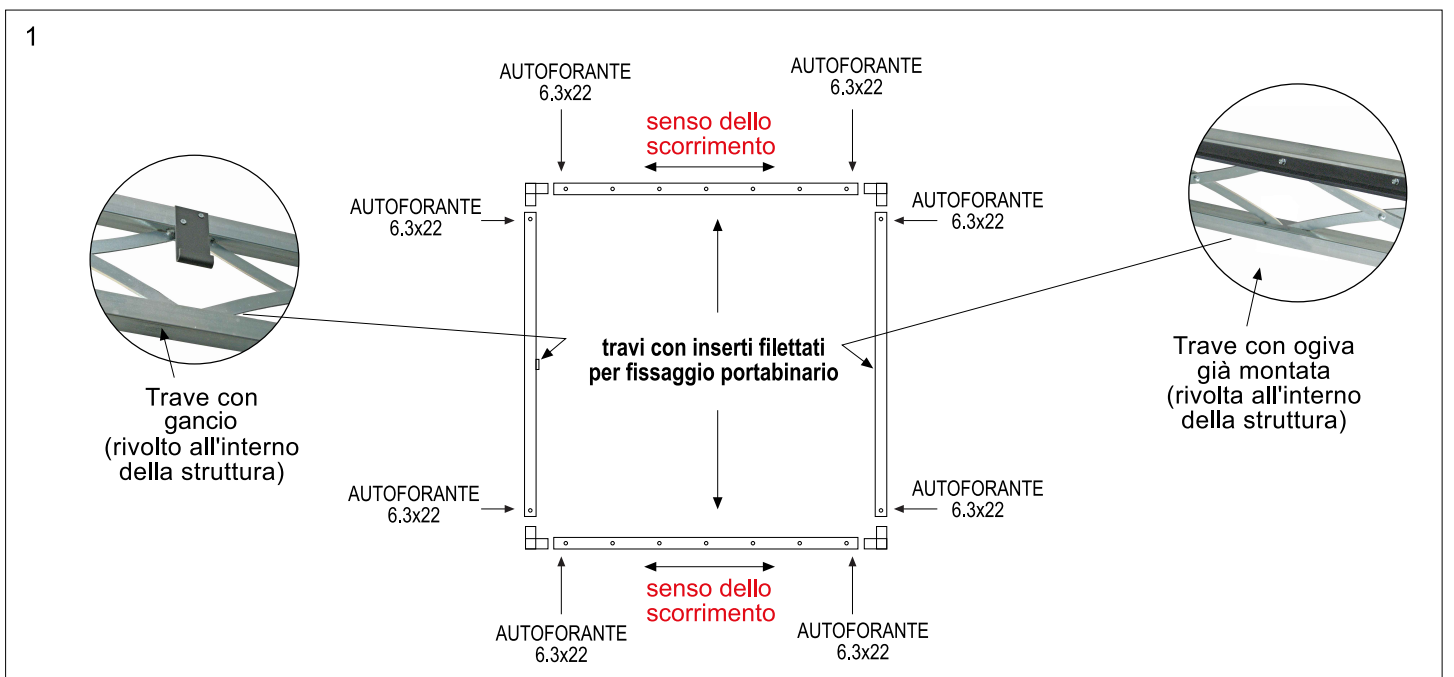

2)

Collegare le travi con i giunti angolari



3)

porta-binario
bulloni 6x30

binario
Fissare il binario con il porta-binario sulle travi perimetrali

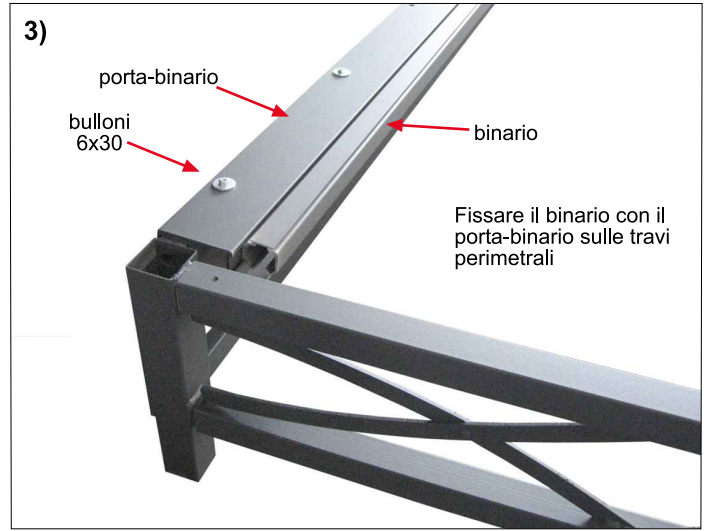

4) Fissare i giunti angolari con le travi perimetrali

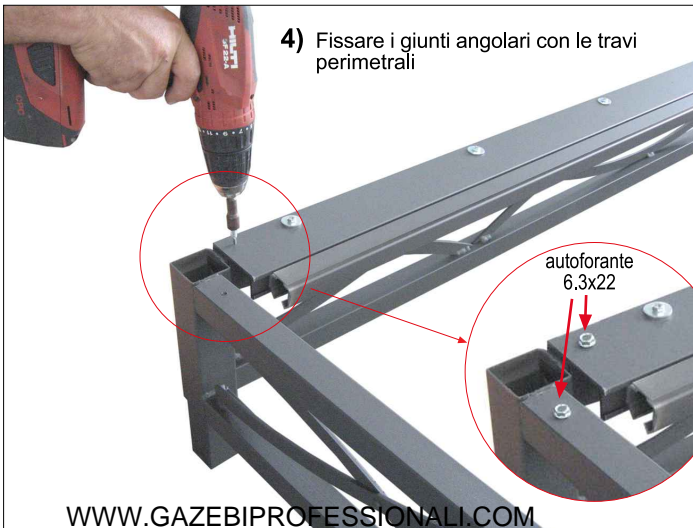

5)

bullone 8x60

Sollevare il perimetro ed inserire i 2 piantoni con i piedi

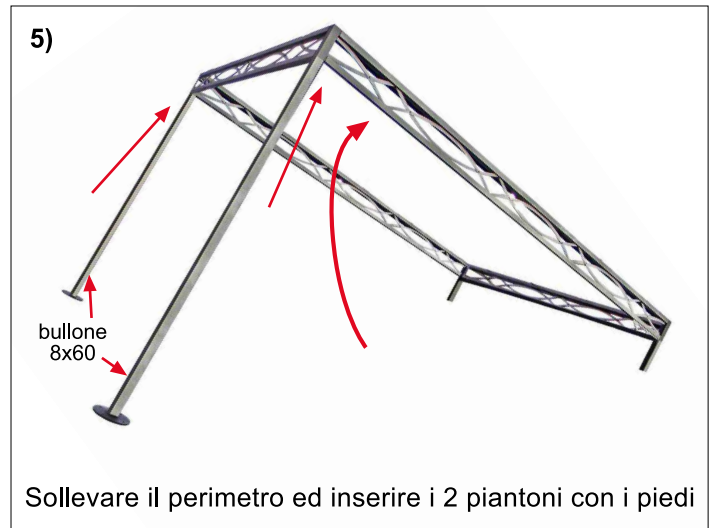

6)

bullone 8x60

Sollevare il perimetro dall'altro lato ed inserire gli altri 2 piantoni con i piedi

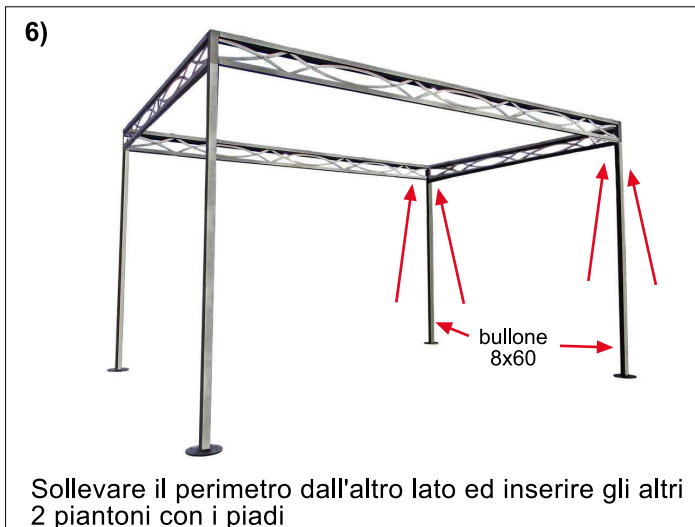

7)

bulloni 8x25

Fissare gli squadri angolari

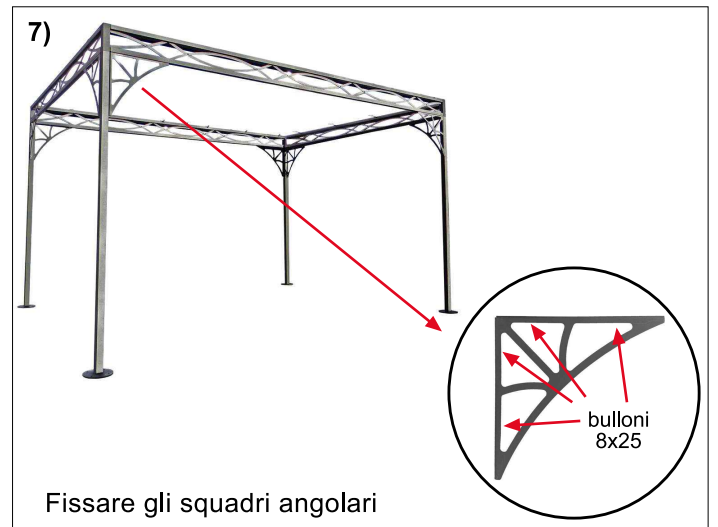

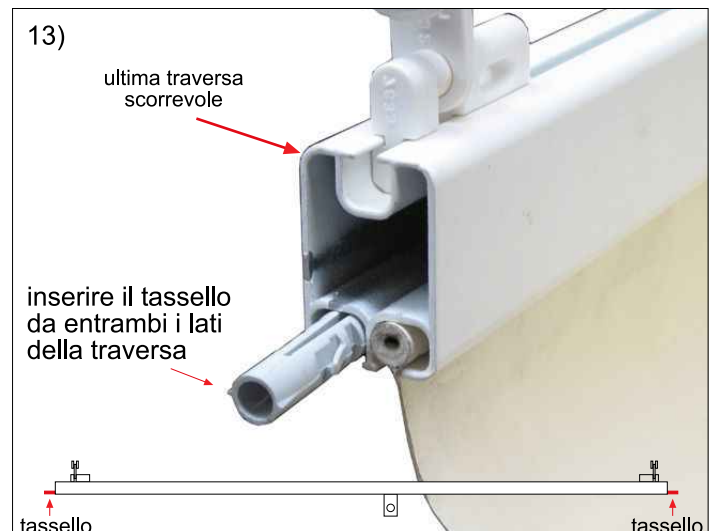
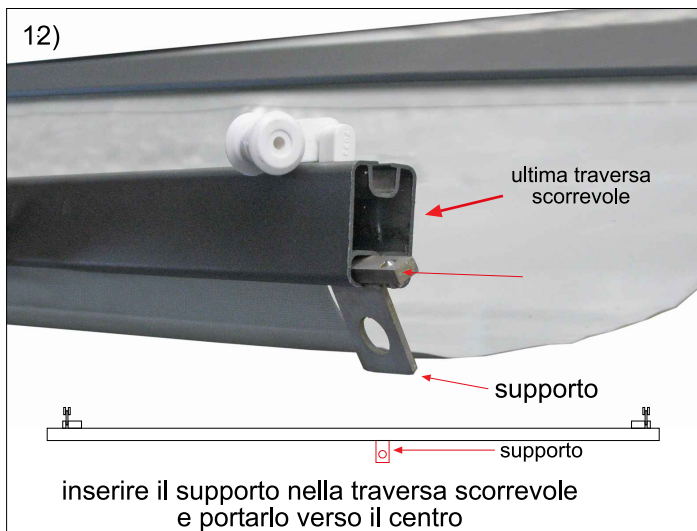
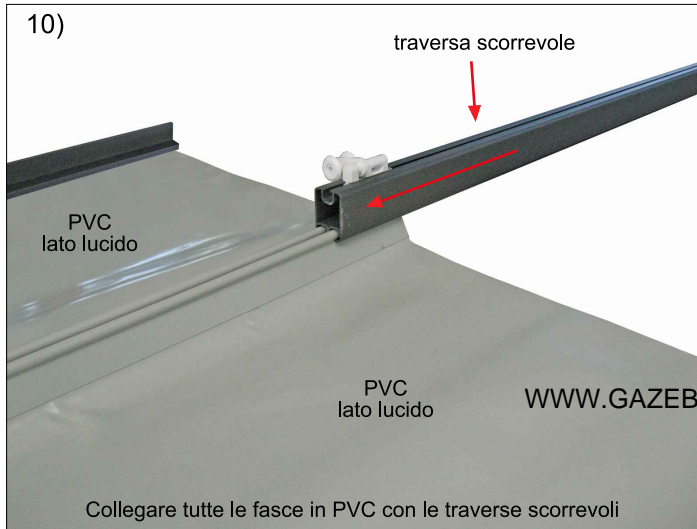
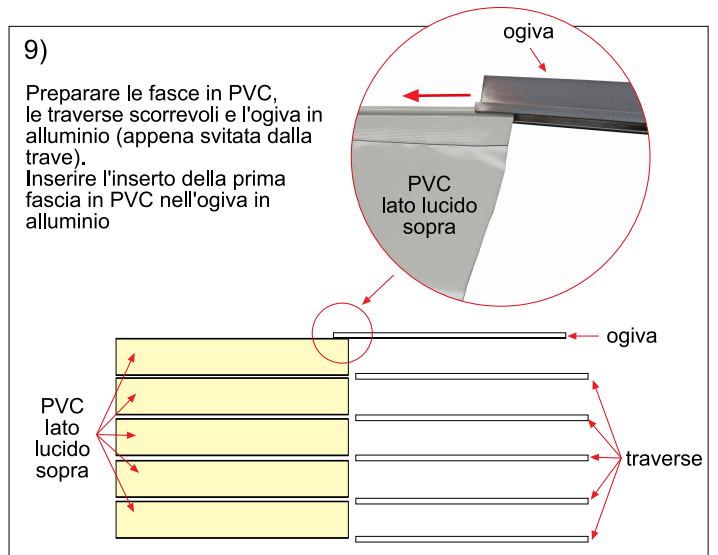

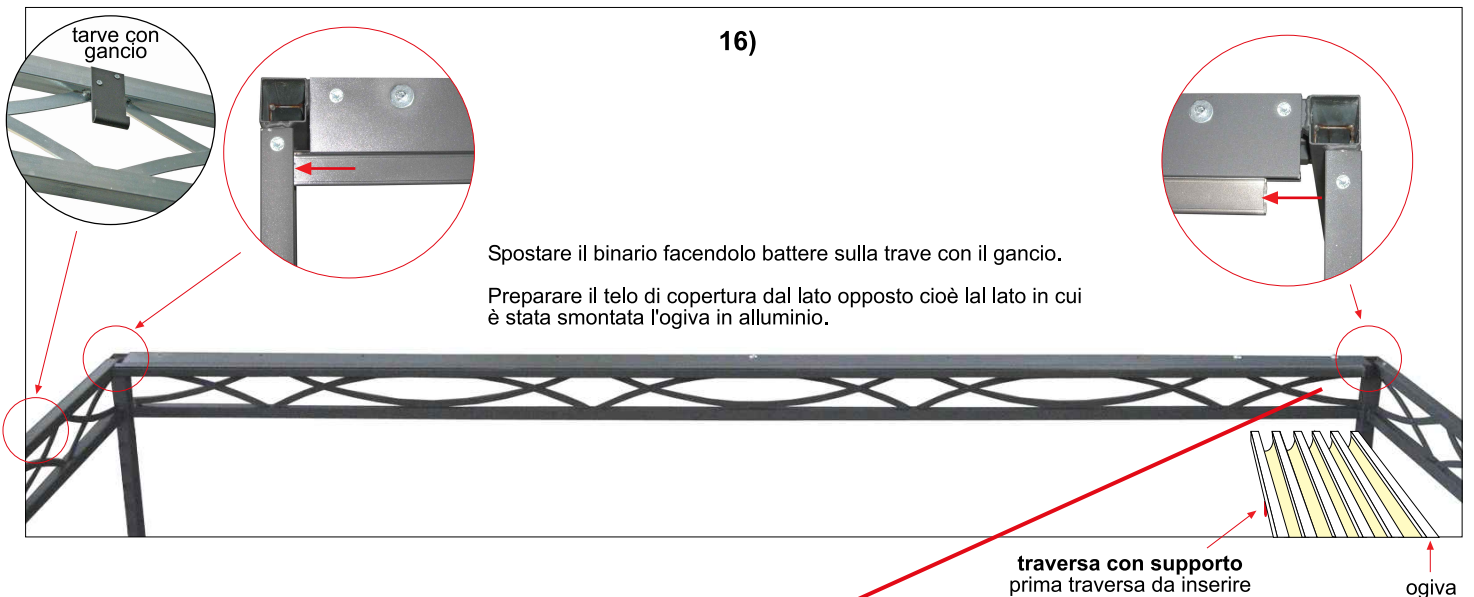
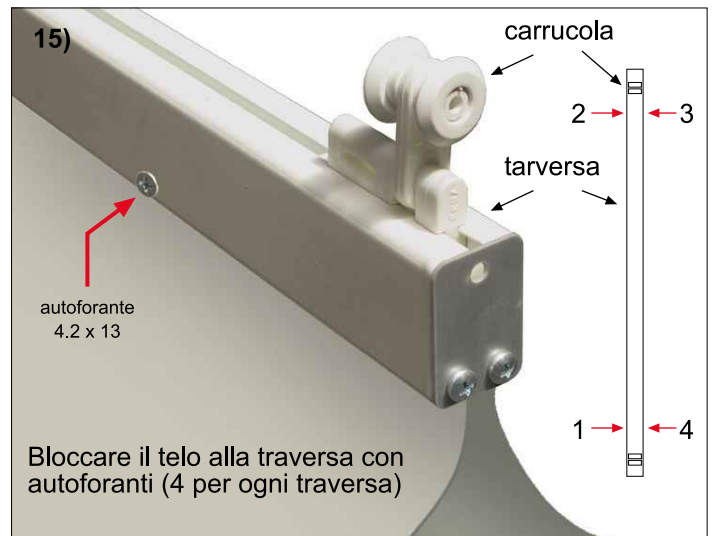
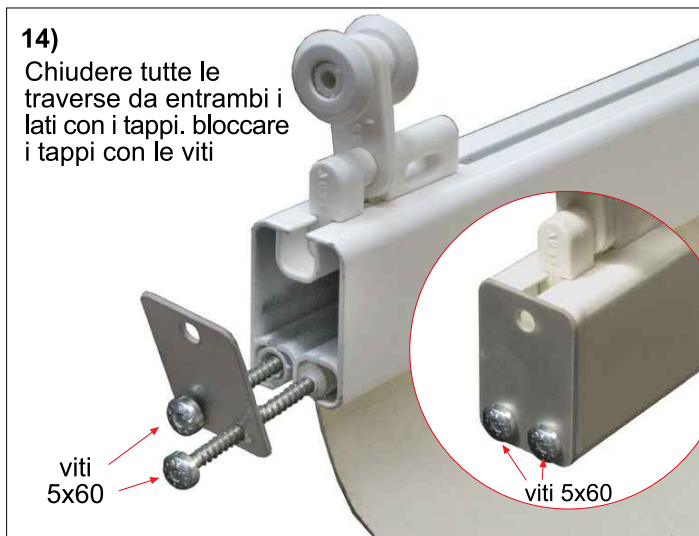

Inserire le carrucole delle traverse nei binari, facendo attenzione che bisogna partire da quella con il supporto

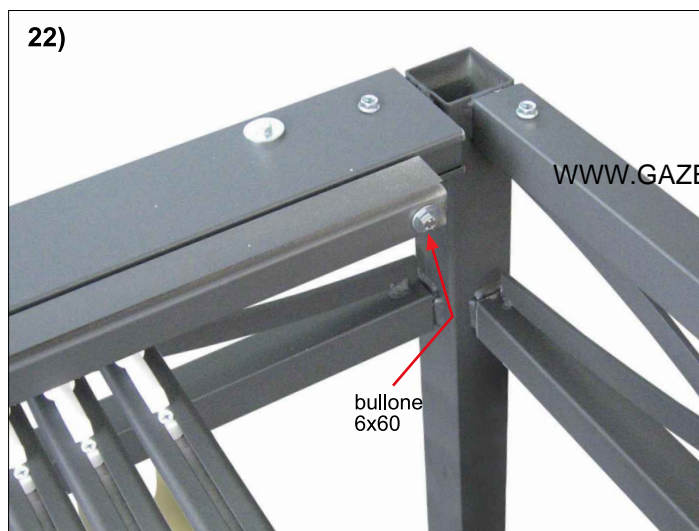
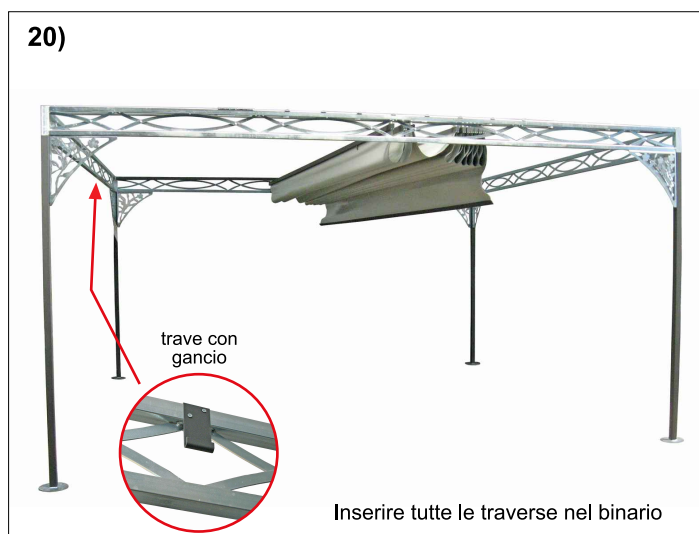
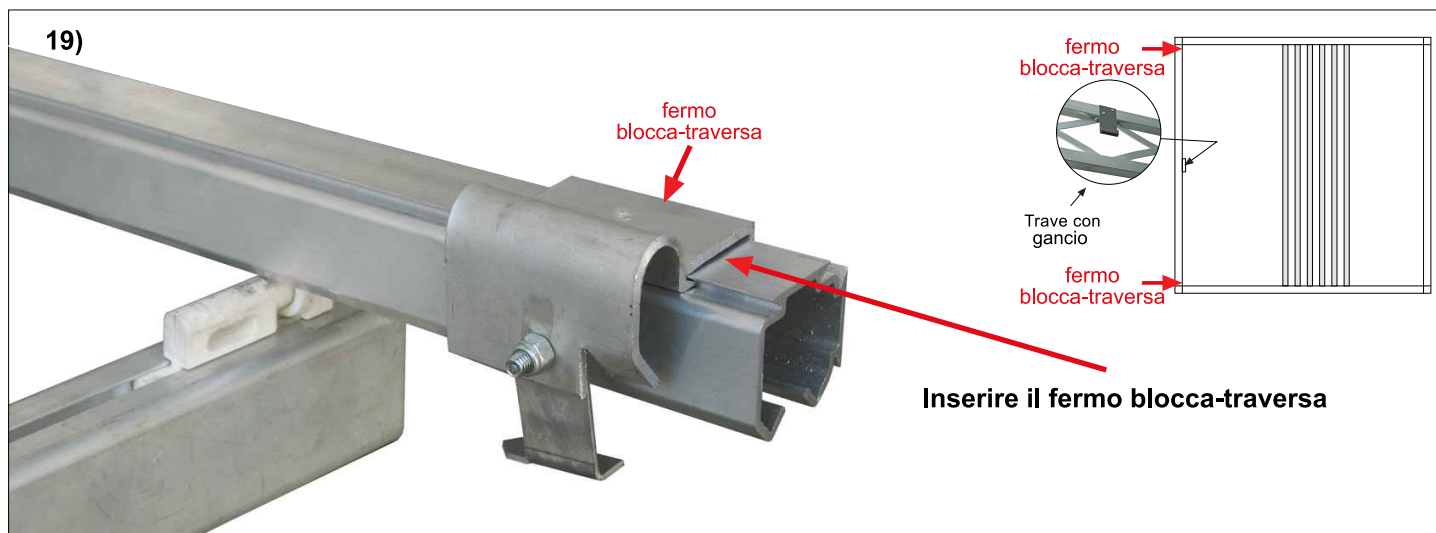

24)

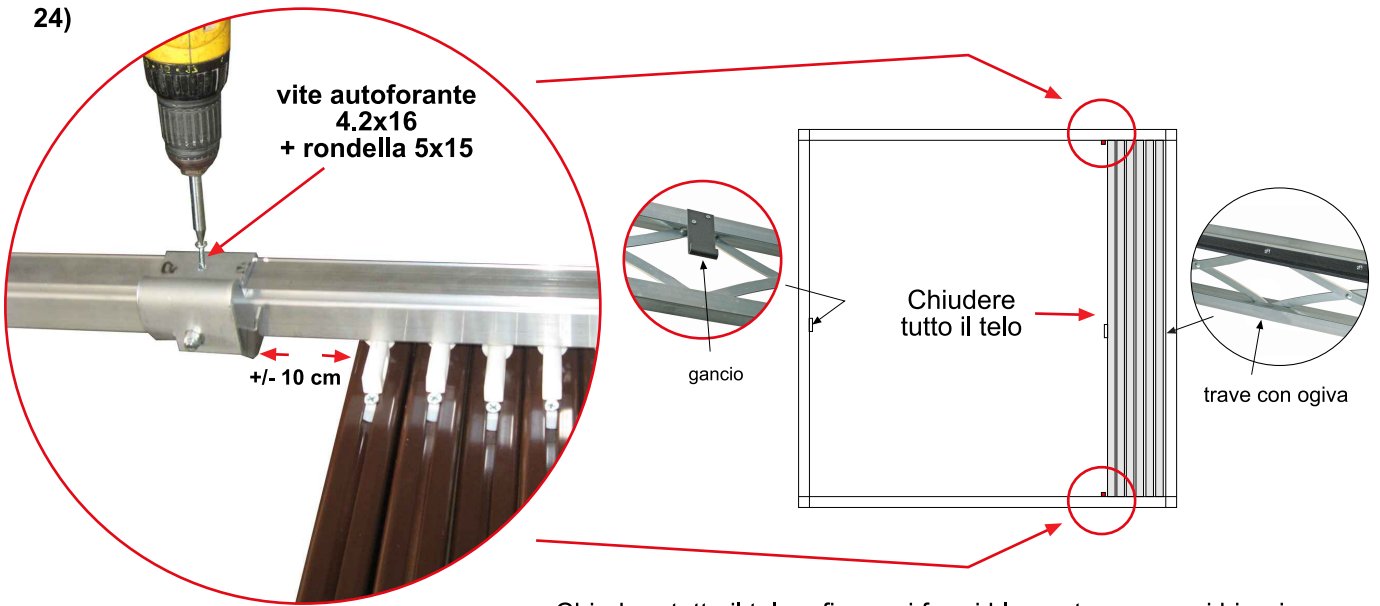

25)



26)



27)



28)



